

# PQS-402 User Manual



This product complies with European Union EMC Directive (89/336/EEC) and the Low Voltage Directive (73/23/EC)

© German Physiks 2007  
Revision 0  
Released 20th October 2007

**We reserve the right to change the information contained in this manual without notice. For the latest version please see our web site at [www.german-physiks.com](http://www.german-physiks.com)**

## TABLE OF CONTENTS

1. INTRODUCTION .....	3
2. UNPACKING YOUR LOUDSPEAKERS .....	3
3. ASSEMBLING YOUR LOUD SPEAKERS .....	5
Introduction .....	5
Assembly Procedure .....	6
4. CONNECTING YOUR LOUDSPEAKERS .....	10
High Frequency Level Control .....	10
Low Frequency Level Control .....	10
Input Terminal Connections .....	11
Single Wire Connection .....	11
Bi- Wire Connection .....	11
Bi- Amp Connection .....	11
5. LOUDSPEAKER BREAK IN.....	11
6. LOUDSPEAKER PLACEMENT AND SET-UP .....	12
Listening Room Layout .....	12
Loudspeaker Placement .....	12
Distance from rear wall: .....	12
Distance from side wall:.....	12
7. CARE OF YOUR LOUDSPEAKERS.....	14
8. WARRANTY .....	14
9. SERVICE AND SUPPORT.....	14
10. HOW TO CONTACT US .....	15
11. PQS-402 SPECIFICATIONS.....	16
12. WARRANTY REGISTRATION.....	16

## 1. INTRODUCTION

Thank you for selecting the German Physiks PQS 402 for your audio system. It uses an array of two DDD drivers to cover all frequencies above 220Hz. The low frequencies are handled by a system using two 10 inch drivers combined with four 8 inch passive radiators. The Loreley is entirely handmade and is built and tested by highly skilled technicians at our factory in Germany.

Every step in the design and manufacture of this product has been dedicated to producing a loudspeaker that will provide a lifetime of musical enjoyment.

We strongly recommend that you read this manual before you attempt to use the loudspeakers. The supplying audio dealer is responsible for assembling and setting up the loudspeakers. This should not be attempted by the customer. Information on these topics contained in this manual is intended for general use only.

## 2. UNPACKING YOUR LOUDSPEAKERS

**NOTE: The customer should not attempt to assemble the loudspeaker. This will be done by the supplying audio dealer.**

**The crates and their contents are heavy. To avoid injury, please ensure that 2 people are available to unpack and position the loudspeakers.**

The PQS-402 is supplied in 3 crates. Before opening them, please inspect them for damage. If you see any damage to the crates, please contact the supplying audio dealer immediately and provide them with a full description of the damage. Do not attempt to unpack the loudspeakers until you have spoken with the dealer and have been advised how to proceed.

The woofer module assemblies for the left and right channels are packed in separate crates which are marked "left" and "right" on the outside. Take care not to mix components from these two crates up. The two DDD towers are packed together in the third crate.

Please retain all of the packing as you will need this should it be necessary in the future to ship the loudspeakers. Should you need to return the loudspeakers to the factory, you must use the original packing. The use of any other packing may result in the loudspeakers sustaining damage in transit. Such damage is not covered by the warranty. Should you require replacement packing, please contact your German Physiks dealer, the national distributor or the factory directly.

Use Figure 1 to identify the major components of the loudspeaker and confirm that the crates contain the following items:

Item	Quantity	Description
1	2	Bottom Plates
2	2	Lower Modules
3	2	Distance Frames
4	2	Upper Modules
5	2	Top Plates
6	2	DDD towers
7	20	Inter-Cabinet Connecting Cables
8	1	User manual
9	4	Cleaning cloths

If any items are missing, or if any item shows signs of damage, please contact the supplying audio dealer immediately.

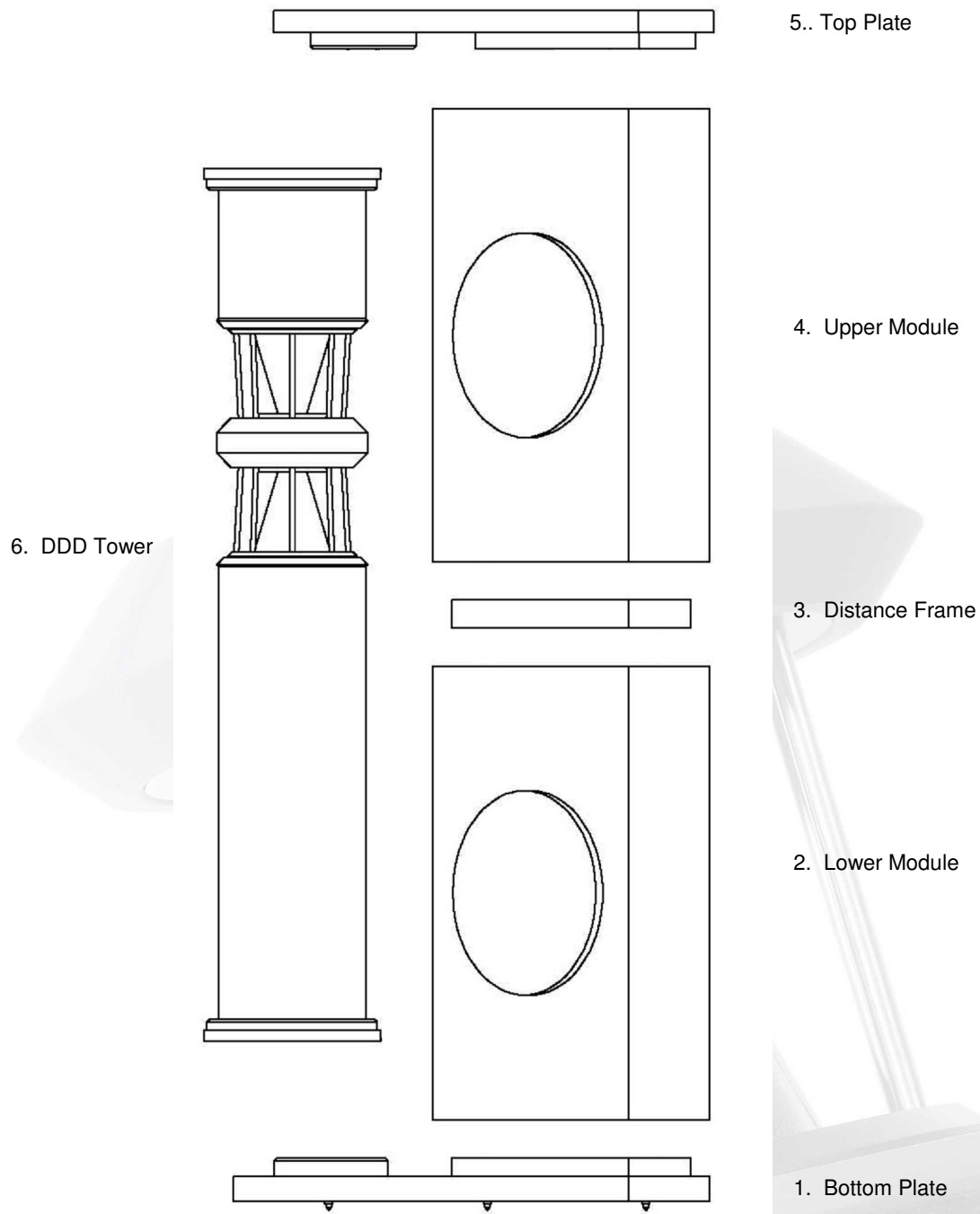

Figure 1. PQS-402 Major Components

### 3. ASSEMBLING YOUR LOUD SPEAKERS

#### Introduction

Because of the complexity of the PQS-402, customers are strongly requested not to attempt to assemble or set up the loudspeakers on their own. These tasks will be carried out by the supplying dealer who has received detailed training from German Physiks engineers. Many of the component parts are very heavy and personal injury could result if they are inappropriately lifted. Component parts could also be damaged by inexpert handling and any resulting damage would not be covered by the warranty.

The following description of the assembly process is for general information only. It is not intended to be used as a guide for assembling the loudspeakers, as it has been simplified for the sake for clarity. Please refer to figure 1 to familiarise yourself with the major components.

We will describe the assembly process for the left loudspeaker. This has its two 10 inch drivers located on the right side of the woofer modules, as can be seen in figure 2 below.

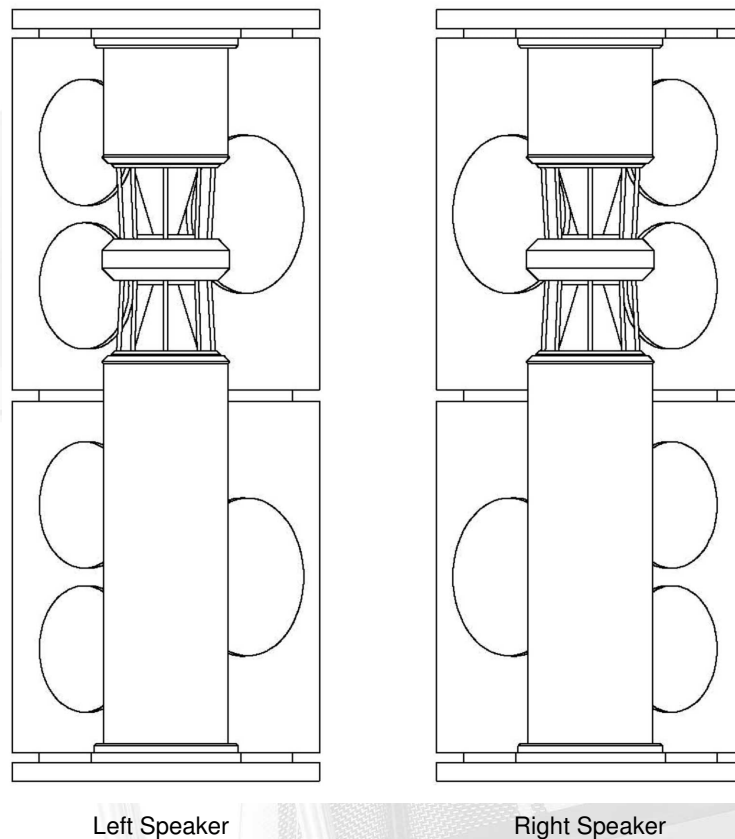

Figure 2. PQS-402 Front View

## Assembly Procedure

1. Place the left loudspeaker bottom plate on the floor in the position where the speaker is to be sited. Ensure that it is sitting squarely on all 5 support points and that it is level.

2. Identify the left lower module. This has the input terminals and level selectors on its rear face. This module is very heavy and you may find it easier to grip if the woofer grills are removed first. Place it carefully on top of the bottom plate as shown in figure 3. Ensure that it is properly seated.

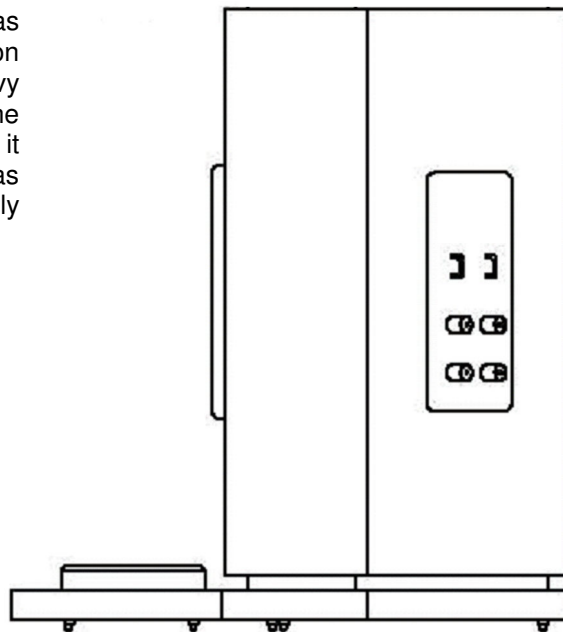

Figure 3. Lower Module on Bottom Plate

3. Replace any grills that have been removed and then place the distance frame on top of the lower module as shown in figure 4. Ensure that it is properly seated.

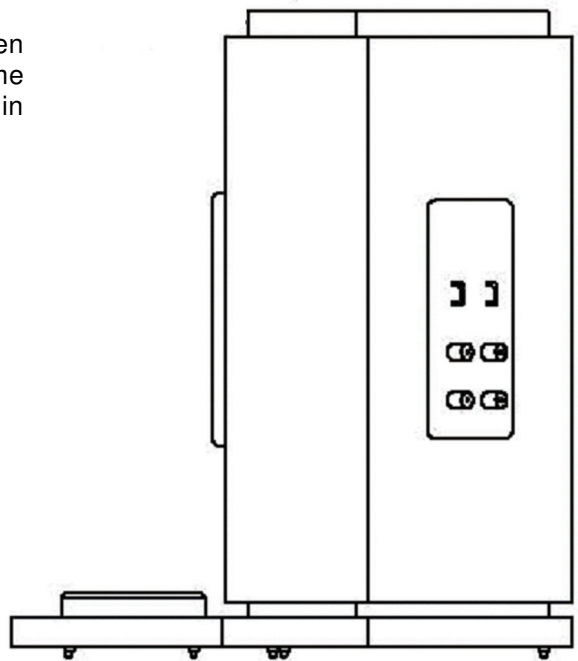

Figure 4. Lower Module with Distance Frame

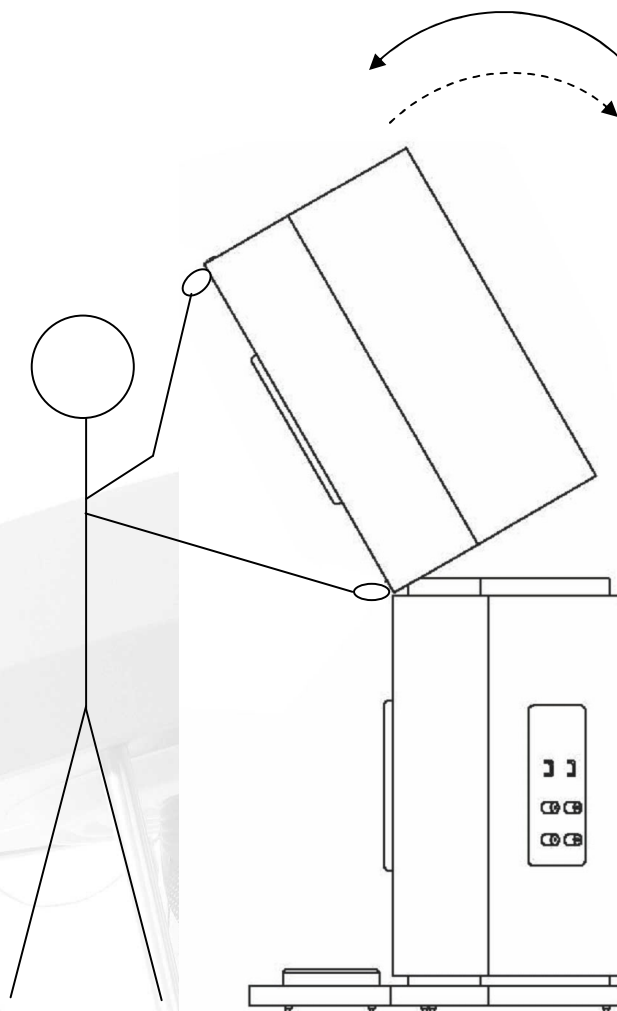

Figure 5. Fitting Upper Module and Connection Cables

4. The next operation must be carried out by two people. You will need 8 of the black inter-cabinet connecting cables ready to hand. Identify the left loudspeaker upper module. Place this on top of the distance frame and ensure that it is properly seated. One person should stand at the front of the speaker and with their hands placed as shown in figure 5, carefully tilt the upper module forward over one edge sufficiently to allow the second person to fit the inter-cabinet connecting cables between the two modules. The upper module may be tilted forward on either edge. Choose the one that is most convenient. Take great care to ensure that it cannot slip forward whilst being tilted. The sockets are colour coded. Please ensure that all the cables are correctly connected.

When all the cables have been fitted, slowly tilt the upper module until it is fully upright, while taking care that none of the cables become pinched between the upper module and the distance frame. Take great also that you do not trap any fingers under the module as it is put into position.

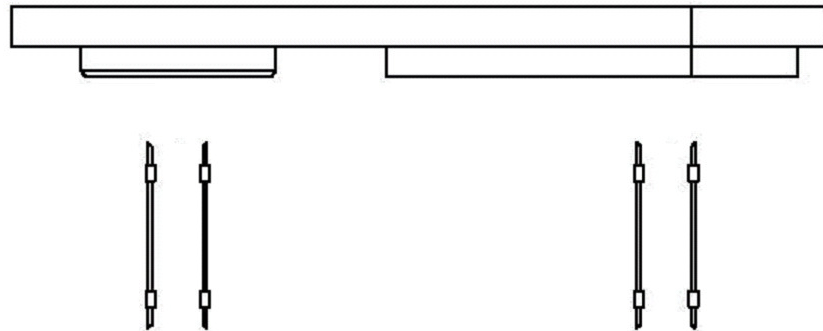

Figure 6. Top Plate Cable Connection

5. Identify the left loudspeaker top plate and fit one black and one red cable to each pair of sockets as shown in figure 6.

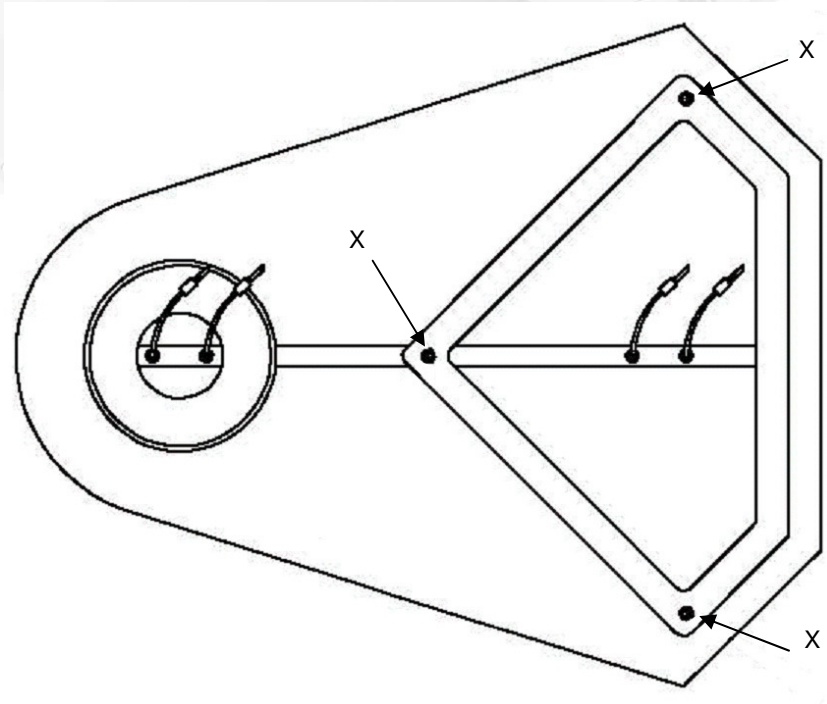

Figure 7. Top Plate Adjusting Screws

The top plate has 3 screws, marked X in figure 7, which will be used by the dealer to adjust the module stack for any variation in verticality. The customer should not attempt to adjust these.

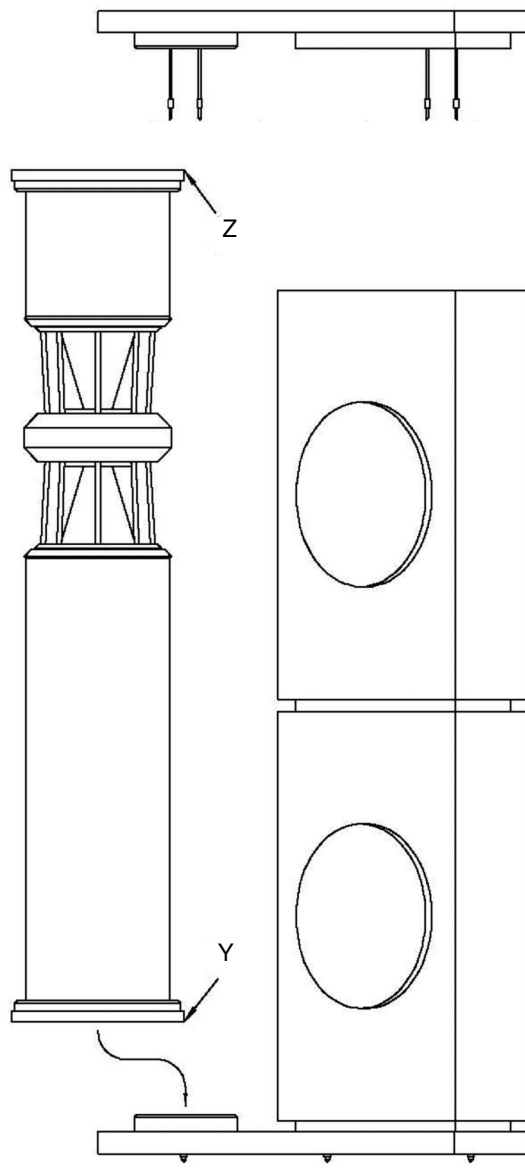

Figure 8. Fitting the DDD Tower and Top Plate

6. Identify the DDD tower. Referring to figure 8, carefully fit the base of the DDD tower, Y, over the locating disc on the bottom plate and ensure that it is sitting squarely. Take great care not to damage the front of the lower bass module with the DDD tower, as there is very little clearance between where the DDD tower fits and the bass module.

Offer up the top plate and plug the 4 connecting cables into their respective sockets on the top of the upper module and DDD tower. These sockets are colour coded. Please check that like colours are connected.

Carefully lower the top plate onto the upper module and DDD tower. Take especial care that the locating disc on the top plate sits squarely inside the top of the DDD tower and is not simply resting on the point Z. Also take care the cables do not become pinched as the top plate is lowered onto the upper module and DDD tower.

## 4. CONNECTING YOUR LOUDSPEAKERS

The German Physiks PQS-402 is a 2 way loudspeaker with separate input terminals for the low frequency and high frequency sections of the crossover. These drive the woofers and DDD drivers respectively and are labeled as such. Provision is also made to allow the output level of the low frequency and high frequency cross overs to be adjusted.

The input terminals and cross over adjustment points are located on a panel fitted on the back of the lower woofer cabinet. Figure 9 identifies the features on this panel.

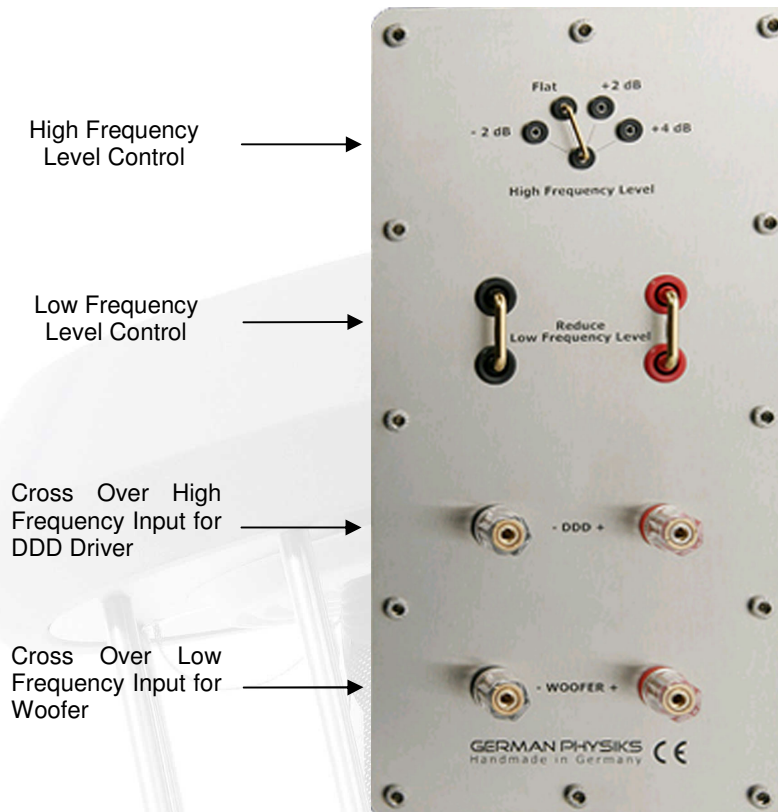

Figure 9. Input Terminals and High Frequency Level Control

### High Frequency Level Control

This adjusts the output from the DDD drivers. 4 settings are provided: -2dB, Flat, +2dB and +4dB. For the initial setting of the speaker this should be set to the flat position. To adjust the control, pull the jumper out and then push it back into the appropriate pair of sockets. The centre frequency for this control is 8,000Hz.

### Low Frequency Level Control

This adjusts the output from the woofers. 3 settings are provided:

No jumpers fitted	+10dB
Red socket jumper only fitted	+5dB
Red and black socket jumpers fitted	Flat

The centre frequency for this control is 60Hz.

## Input Terminal Connections

**NOTE:** The loudspeaker terminals should be tightened as firmly as possible by hand. Do not use pliers or any other tools as this may damage the terminals.

The provision of separate inputs for the low frequency and high frequency sections of the crossover allows the PQS-402 to be operated in 3 modes:

Single wire connection  
Bi-wire connection  
Bi-amp connection

### Single Wire Connection

This is the most commonly used method of connecting a loudspeaker and power amplifier. Only one loudspeaker cable is used for each loudspeaker. The PQS-402 will be shipped configured for this mode of operation. In this case the red terminals on the DDD and woofer inputs will be connected together and the black terminals on the DDD and Woofer inputs will be connected together. These connections must be made using the special links provided. The loudspeaker cable should be connected to the woofer input terminals.

An amplifier capable of delivering at least 340W rms into 4 ohms per channel should be used for each speaker.

### Bi- Wire Connection

In this method of connection the woofer and DDD inputs are connected to the power amplifier with separate loudspeaker cables. Ensure that the links fitted between the woofer and DDD input terminals have been removed.

An amplifier capable of delivering at least 340W rms into 4 ohms per channel should be used for each speaker.

### Bi- Amp Connection

In this method of connection the woofer and DDD inputs are driven by separate power amplifiers. Ensure that the links fitted between the woofer and DDD input terminals have been removed.

An amplifier capable of delivering at least 200W rms into 4 ohms per channel should be used for the woofer input and one capable of delivering at least 140W rms into 4 ohms per channel should be used for the DDD input.

We recommend that you use loudspeaker cables terminated with high quality spade lugs, as these provide the best electrical connection. The lugs should be either soldered or crimped to the speaker cable – the latter is preferred. We do not recommend the use of bare wire to connect to the speaker terminal. This produces an inferior connection that will further degrade as the bare conductors become tarnished.

## 5. LOUDSPEAKER BREAK IN

Like all audiophile equipment, German Physiks loudspeakers require a break in period from new before they reach their optimum level of performance. The music used for the break in should be dynamic in order to properly exercise all the components of the loudspeaker.

For the first 10 hours play the loudspeaker at low level only. This is a level where you would easily be able to carry out a conversation without needing to raise your voice.

After this, the speaker may be played at normal listening levels. The break in process will be complete after 200 to 300 hours.

## 6. LOUDSPEAKER PLACEMENT AND SET-UP

**NOTE: DO NOT place the loudspeakers close to cathode ray type monitors or projectors, as the very powerful magnets used in the drivers may affect the picture. We recommend a minimum separation of 2m.**

Before the loudspeakers can be set up, the break in procedure in section 5 must be completed.

The German Physiks PQS-402 is an extremely high performance loudspeaker and optimum performance will only be achieved when set up by a trained technician. For this reason the supplying audio dealer will carry out the set-up for the customer.

### Listening Room Layout

The following points will help you optimise your listening room layout.

1. The left and right sides of the room should be symmetrical. If the room is asymmetrical, this will degrade the quality of the stereo image. This is because most of the sound energy that you hear is reflected before it reaches your ears.
2. Place the speakers symmetrically in the room, i.e. the same distance from the centre line of the room and the same distance from the rear wall.
3. Avoid placing the speakers similar distances from the side and rear walls, as this may lead to an uneven bass response
4. Avoid having any hard surfaces between your listening position and the loudspeakers. This will generate additional reflections that may degrade the stereo image. For this reason, where ever possible equipment should be located at the side of the room. If you have a hardwood floor, it may be advantageous to place a carpet on the floor covering the area between the loudspeakers and the listening position, as this will reduce unwanted early reflections.
5. Avoid having the listening position closer than 1.2m from the rear wall as early reflections from this wall will degrade the stereo image.

### Loudspeaker Placement

**Distance from rear wall:** We recommend that you start with the speaker positioned 1.5m from the rear wall. As you move the speaker closer to the wall the level of the bass response will be increased. The converse will be true as you move the speaker away from the rear wall. The PQS-402 should not be placed closer that 1m from the rear wall. If the speaker is too close to the rear wall, not only will the bass response be excessive, but the stereo image will be degraded due to an increase in early reflections. Aim to find a position that provides an even bass response so that all the bass notes in the music are reproduced at an equal level. Be sure to choose a recording that itself has an even bass response.

**Distance from side wall:** We recommend that the distance between the centres of the DDD towers be 2/3 of the distance of the loudspeakers from the listening point. Moving the speakers further apart will degrade the stereo image.

We do not recommend placing the loudspeakers closer than 1m from the side walls, as the early reflections will degrade the stereo image.

Positioning the speakers too close to the side walls will also lead to an uneven bass response. Aim to find the position that provides the best defined and most realistic stereo image when you are seated at the listening position.

Figure 10 gives a general guide to speaker positioning and the location of the listening position. Note how the recommended listening position varies with the separation between the DDD towers and also how as the listening position is moved away from the loudspeakers the woofer modules need to be toed in by rotating the woofer modules towards the adjacent side walls while keeping the DDD tower centres in the same position.

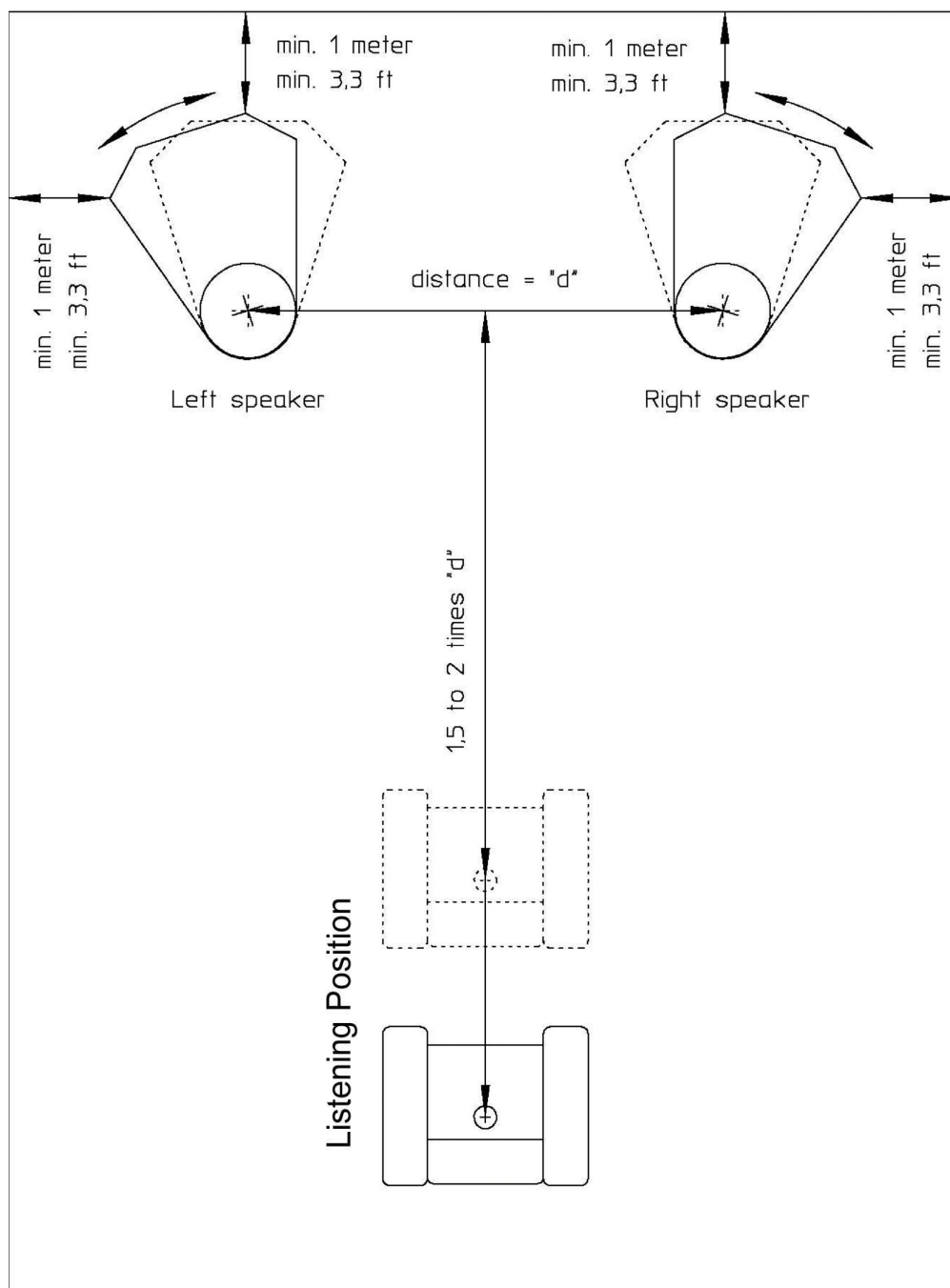

Figure 10. Listening Room Arrangement

## 7. CARE OF YOUR LOUDSPEAKERS

**NOTE: NEVER attempt to open the cabinets. There are no user serviceable parts inside the loudspeakers.**

**NEVER touch the diaphragm on the DDD driver, or allow any object to come into contact with the diaphragm.**

**NEVER attempt to clean the dust off the diaphragm. Dust has no affect on its performance and may be safely ignored.**

**NEVER attempt to clean the speakers with any abrasive materials or any cleaners containing ammonia, alcohol or other solvents, as these may damage the finish.**

The only maintenance the speakers will require is periodic dusting to remove dust and any finger prints from the cabinets. Please use the cleaning cloths supplied with the loudspeakers. These cloths should be used dry. Do not use any form of liquid with them. Additional cloths may be obtained via local your German Physiks dealer, national distributor or direct from German Physiks.

## 8. WARRANTY

Your German Physiks loudspeakers are warranted to be free from defects if used under normal conditions for a period of 5 years from the date of purchase, provided that the customer registers their purchase by completing and returning the registration form in this manual within 7 days of purchase. They must also return a copy of the receipt issued at the time of purchase. If this is not done the warranty period will be 5 years from the date of shipment from the factory. This warranty is transferable to subsequent owners, who must register their purchase with us.

Modifications or repairs performed by the factory, or by an authorised repair agent, shall be guaranteed for the remaining period of the warranty, or for 1 year, which ever is greater.

Any unauthorised modifications or repairs will invalidate the warranty. The warranty will also be invalidated if German Physiks determines that the unit has been subject to misuse including, but not limited to, burnt out voice coils and dents or scratches on driver diaphragms or cabinets.

There is no other express warranty on German Physiks products. This warranty shall not extend beyond the stated warranty period. No responsibility is assumed for incidental or consequential damage.

## 9. SERVICE AND SUPPORT

In the first instance please contact your local German Physiks dealer or distributor. They will diagnose the fault and liaise with German Physiks to decide the best way to affect a repair. If they unable to assist you, please contact German Physiks by phone on + 49 61 09 50 29 823, by fax on + 49 61 09 50 29 826, or by email at [service@german-physiks.com](mailto:service@german-physiks.com). You may also contact us via our web site at [www.german-physiks.com](http://www.german-physiks.com). Please take into account time differences between Germany and where you are calling from should you need to phone us. Email is our preferred method of initial contact. Please supply the model name and serial numbers of your loudspeakers and as much detail of your problem as possible.

In the vast majority of cases, the repair will be dealt with by sending spare parts from the factory. In the unlikely even that it becomes necessary to return your loudspeakers or any part of them to the factory, you will be given a Return Authorization (RA) number. This number must be clearly marked on the outside of the packing. Returns made without a RA number will not be accepted. Any returned items must be shipped in the original packing. German Physiks will not be responsible for any damage that occurs as a result of the use of non-standard packing. Returns received in non-standard packing will be replaced with new packing at the owner's expense. If you need new packing, please contact your German Physiks dealer or the factory.

For items returned to the factory under warranty during the first year, German Physiks will pay for the shipping charges both ways. A shipping company approved by German Physiks must be used and the items will be returned to the customer using the same carrier, or an equivalent service.

For loudspeakers returned to the factory under warranty after the first year, the customer is responsible for paying all shipping and related charges back to the factory. A shipping company approved by German Physiks must be used. Providing this condition is met, German Physiks will pay the cost of shipping the loudspeakers back to the customer.

German Physiks will not pay any shipping costs if:

- a. Loudspeakers or parts are returned without a RA number
- b. No fault is found
- c. If the fault is judged to be due to misuse such as, but not limited to, burnt out voice coils and dents or scratches on driver diaphragms or cabinets.

Customers are responsible for all freight, duties and related shipping charges for loudspeakers returned for non-warranty repairs.

## 10. HOW TO CONTACT US

If you wish to get in touch with us please use the contact information shown below. Please note that our office hours are from 9.30 a.m. to 5.00 p.m. Monday to Thursday, excluding public holidays and that we cannot respond to enquiries outside of these hours. We recommend that where ever possible you contact us by email, as this will allow us to give your enquiry more consideration and thus provide a more detailed reply.

Address	DDD-Manufactur GmbH Gutenbergstraße 4 D-63477 Maintal GERMANY
Telephone	+ 49 61 09 50 29 823
Fax	+ 49 61 09 50 29 826
Email	service@german-physiks.com
Web	www.german-physiks.com

## 11. PQS-402 SPECIFICATIONS

Version	With Titanium DDD Drivers	With Carbon DDD Drivers
<b>Impedance</b>	2.2 ohms at 1,200 Hz	2.2 ohms at 1,200 Hz
<b>Frequency Response</b>	25 – 21,500 Hz	25 – 24,000 Hz
<b>Power Handling</b>		
Nominal	450W	450W
Short term	750W	750W
<b>Amplification required</b>	DDD Section: Minimum 140 watts into 4 ohms Woofer: Minimum 200 watts into 4 ohms	
<b>Cross over frequency</b>	220 Hz	
<b>Cross over slopes</b>		
DDD section	12 dB/octave electronic and 24 dB/octave acoustic	
Woofer section	18 dB/octave electronic and 24 dB/octave acoustic	
<b>High frequency adjustment</b>	-2dB, flat, +2dB and 4dB. Centre frequency: 8,000Hz	
<b>Low frequency adjustment</b>	+10 dB, + 5 dB and flat. Centre frequency: 60 Hz	
<b>Sensitivity</b>	88.4 dB for 1 watt a 1m	88.8 dB for 1 watt at 1m
<b>Maximum output level</b>	112dB	118dB
<b>Operating principle</b>	2 way speaker using DDD Bending Wave Converters giving a 360° radiation pattern.	
<b>Input connectors</b>	2 sets of binding posts allowing bi-amping and bi-wiring	
<b>Drivers</b>	2 x Titanium DDD drivers 2 x 10 inch woofers 4 x passive 8 inch radiators	2 x Carbon DDD drivers 2 x 10 inch woofers 4 x passive 8 inch radiators
<b>Dimensions</b>	620mm W x 1560mm H x 750mm D 24.4" W x 61.4" H x 29.5" D	
<b>Weight</b>	Approx 165kg Approx 363lbs Actual weight depends on detailed specification	
<b>Warranty</b>	5 years	

As part of our process of continually improving our products, we reserve the right to change specifications without notice

## 12. WARRANTY REGISTRATION

In order to register your purchase and obtain the full 5 year warranty, Please complete the form below within 7 days of purchase and return it by post together with a copy of the receipt of purchase to:

DDD-Manufactur GmbH  
 Gutenbergstraße 4  
 D-63477 Maintal  
 GERMANY

<b>Name</b>	
<b>Address</b>	
<b>Country</b>	
<b>Zip/Post Code</b>	
<b>Speaker Model</b>	<b>German Physiks PQS 402</b>
<b>DDD Type</b> Delete as necessary	<b>Titanium/Carbon</b>
<b>Serial Number</b>	
<b>Finish</b>	
<b>Date of Purchase</b>	
<b>Where Purchased</b>	
<b>Address</b>	
<b>Country</b>	
<b>Zip/Post Code</b>	

